

## INSTRUCTION SHEET FOR TOOL #963

### BEARING AND RACE PULLER TOOL

THIS TOOL HAS BEEN DESIGNED TO REMOVE THE FLYWHEEL SPROCKET SHAFT INNER BEARING RACE ON 2003 TO PRESENT TWIN CAMS.

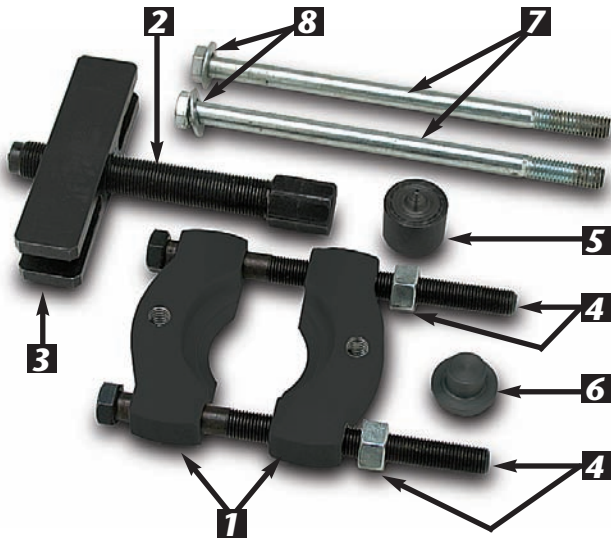

#### PARTS AVAILABLE SEPARATELY

NO.	QTY.	DESCRIPTION	JIMS PART NO.
1	1	WEDGE PLATE	963-1
2	1	SCREW	1024
3	1	PULLER BAR	2013
4	2	WEDGE PLATE HARDWARE KIT	963-2
5	1	HARDENED TIP, EARLY	1048-1
6	1	HARDENED TIP, LATE	995-3
7	2	SCREW	2030
8	2	WASHER	2031

This tool can also be used on the following:

- Use to remove Timken bearing (H.D. No.9028) or No.9029 on Big Twins, 1955 Panhead to present Twin Cam, including JIMS 120" engines.
- Use to remove the flywheel sprocket shaft inner bearing race or the Timken bearing. Also removes pinion shaft inner bearing race on Sportster 1954 to present, including all Buell's to present.
- Use to correctly remove press fit transmission gears and bearings from input and output shafts on all V-ROD models 2002 to present.

**NOTE: PLEASE READ ALL INSTRUCTIONS COMPLETELY PERFORMING ANY WORK!  
IF YOU DO NOT KNOW WHAT YOU ARE DOING, DO NOT DO IT!**

No information in this instruction sheet pertaining to motorcycle repair is represented as foolproof or even altogether safe. Even something safe, done incorrectly or incompletely can and will backfire. You and only you are responsible for the safety of your repair work and for your understanding the application and use of repair equipment, components, methods and concepts.

Each and every step that this tool is designed to do must be carefully and systematically performed safely by you. All information listed in this instruction sheet has been tested, re-tested and used daily in JIMS® Research and Development Department.

**ALWAYS WEAR SAFETY GLASSES OR OTHER FACE AND EYE PROTECTION SUCH AS FULL FACE SHIELD. JIMS® IS NOT RESPONSIBLE FOR DAMAGE, INJURY, OR YOUR WORK. JIMS® IS NOT RESPONSIBLE FOR THE QUALITY AND SAFETY OF YOUR WORK.**

**CAUTION: WEAR SAFETY GLASSES. EXCESSIVE FORCE MAY DAMAGE PARTS!  
SEE JIMS® CATALOG FOR HUNDREDS OF TOP QUALITY PROFESSIONAL TOOLS.  
THE LAST TOOLS YOU WILL EVER NEED TO BUY.**

*Performance Parts For Harley-Davidson® Motorcycles*

## INSTRUCTION SHEET FOR TOOL #963

**NOTE:** Jim's tool No. 963 can be useful to remove almost any bearing or race on most any shaft that is about a .500" to 2.000" diameter.

### Jim's Tools needed to perform this service

See Jim's catalog for a complete listing of all engine and transmission tools

### Other Hand Tools needed to perform this service

- 1) 3/4" Wrench or socket/ratchet
- 2) 5/8" Wrench or socket/ratchet
- 3) 11/16" Wrench or socket/ratchet
- 4) 9/16" Wrench or socket/ratchet
- 5) 1" Open end wrench
- 6) Ft-lb Torque wrench
- 7) Propane torch

### Removal Procedures

**Note:** Below you will find one example of how to remove a bearing race from a left flywheel with a fine spline non-threaded shaft end on a late Twin Cam engine. Other applications will be approximately the same.

**Note:** Mount flywheel assembly securely, as you will be applying 75 ft-lbs of torque to the puller tool.

### Pulling the bearing race from the left flywheel of a 03 to present Twin Cam.

**Note:** Apply lube to both wedge plates No.963-1 on the "wedge surfaces". Also apply lube to both I.D. and O.D. of all threads of tool. **See Fig 1.**

1. Install one each of screw No.963-2 thru both wedge plate halves No.963-1 followed by loosely installed nuts No.963-2. **See Fig 1.**

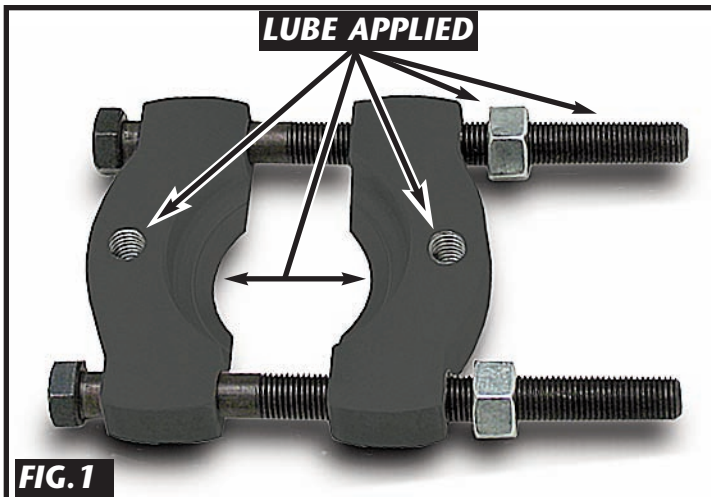

**CAUTION: WEAR SAFETY GLASSES. EXCESSIVE FORCE MAY DAMAGE PARTS!**

*Performance Parts For Harley-Davidson® Motorcycles*

# INSTRUCTION SHEET FOR TOOL #963



**FIG. 3**

2. Position the puller plate assembly with one of the plates on each side of race to be removed, with "wedge plates in place to allow it to be squeezed under bearing race. **See Fig 2.** Hold the screws with a 5/8" box end wrench. Tighten nuts evenly to 35 ft-lbs with a deep 11/16" socket and torque wrench. **See Fig 2.**
3. Place hard cap No. 995-3 with lube applied to the top and bottom side, locate on the top end of sprocket shaft. **See Fig 3.**

**Note:** If your working with a early left Twin Cam flywheel shaft with a threaded wide spline model then at this point install lubed No.1048 over the end of the shaft. **See Fig 3.**



**FIG. 4**

4. With lube applied to all threads of tool No. 2013, 1024, also hardware No.963-2 and 2030 with No.2031 washers installed. Now install No.1024 screw into No.2013 puller bar. **See Fig 4.**
5. With this assembled tool as shown in Fig,4 centered over the hard end cap resting on top of sprocket shaft. Position lubed No.2030 screws then thread 100% into each wedge plates No.963-1 threaded hole. **See Fig 5.**
6. Lift up tool No. 2013 and centered over sprocket shaft, at the same time threading screw No.1024 down until all slack has been taken up. **See Fig 5.**
7. With tool resting squarely over shaft, use your 3/4" socket and torque wrench set at 75 ft-lbs. At the same time holding the side of tool No. 2013 with your 1" open end wrench, thread down screw No.1024 until race is pulled from shaft. See early version. **See Fig 5.**

**Caution:** If race will not move up the shaft at 75 ft-lbs apply heat with a propane torch, until race moves up the shaft.

**Note:** Do not overheat the shaft. Overheating the shaft takes place when the color changes on the surface of the shaft. Apply heat around O.D. of race only. Use two JIMS Heat stickers No. 899 and apply to neck stem just above race on shaft. Watch sticker when heating race O.D. The sticker will change color to alert you to stop heating or you will damage the neck stem. Order stickers seperately. Never exceed 210 degrees.



**FIG. 5**



If applying heat use to race use No.899 heat stickers See catalog for details.

**CAUTION:** ALWAYS WEAR SAFETY GLASSES OR OTHER FACE AND EYE PROTECTION SUCH AS FULL FACE SHIELD.

*Performance Parts For Harley-Davidson® Motorcycles*