



A Division of Thiessen Products, Inc.

INSTRUCTION SHEET FOR TOOL No. 788

EXHAUST SEAL INSTALLER TOOL

This tool installs either tapered exhaust pipe seal, H-D No. 65324-83B or flat type Screamin' Eagle No.17048-98 Performance Exhaust Seal kit, or equivalent into Evo Big Twin, XL, or Twin Cam models. It will position the seal evenly into cylinder head exhaust port, thus preventing exhaust leaks.

No. 788 - Use on all 1984 to present Evo Big Twin and Twin Cam, and 1986 to present XL and air cooled Buell models.

Installation:

1. Position exhaust seal on tool. Note that tool has two sides to correctly position either type of seal used. The side with the small step is for locating the early EVO flat style / Screamin' Eagle high performance gasket set No. 17048-98. The opposite side of the tool is for installing the late, stock tapered style gaskets, No. 65324-83B.

Note: To install tapered style gaskets No. 65324-83B or equivalent, the thin edge faces the tool, while the thick edge orients toward the cylinder head using the side of tool without the step. **See Fig 1.**

2. This tool can install the seals two different ways as shown in. **See Fig. 2 and Fig 3.**

Option 1 : After your new seal is in position on tool plate you can use two exhaust flanged nuts, H-D No. 7593 to install the tool to head. Alternate tightening nuts onto exhaust mounting studs until tool bottoms out on the head. Then install the pipes following H-D service manual. **See Fig 3.**

Option 2 : Using tool handle JIMS No. 33416-80 (sold separately, not included with No. 788 tool) install small end into center hole of No. 788 with new seal in position. Place

these pieces onto exhaust mounting studs. Use a mallet to lightly tap on end of handle until tool seats in head. Then install pipes following H-D service manual.

See Fig 2.

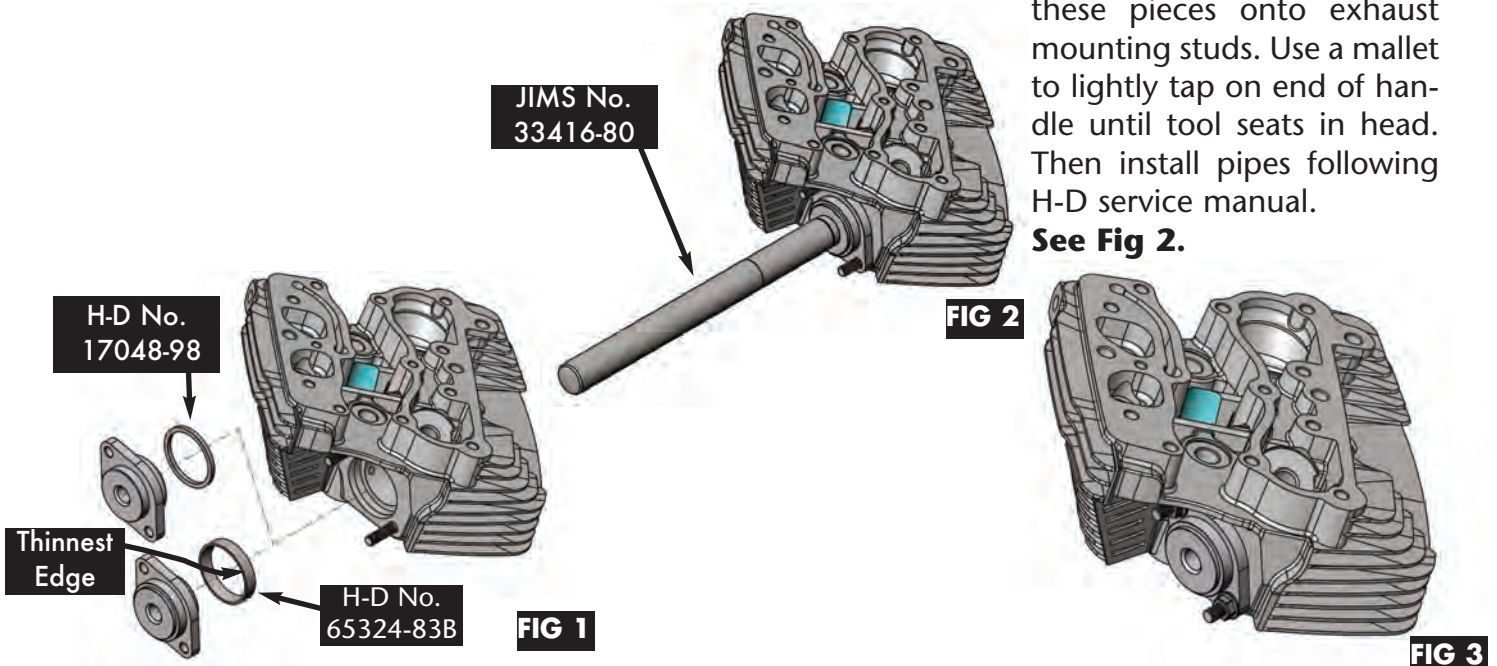

Performance Parts For Harley-Davidson Motorcycles