



A Division of Thiessen Products, Inc.

INSTRUCTION SHEET FOR TOOL No. 776

JIMS LIFT CADDY

This is one of those tools that make you think, why didn't I think of that! JIMS Lift Caddy will not improve your golf swing, but it will give you more time to RIDE!

No longer will you need to find some one to help you move a bike lift with or without a bike on it. With the Lift Caddy installed on all your bike lifts, you'll be thinking you're super man or woman, even with a 900+lbs HOG setting on top, you can move it around the shop floor. Now be honest. How many times have you started repairing a motorcycle at your station and you have the wheels off and now the motorcycle cannot be taken off the bike lift because you're waiting for the parts needed to complete the job? With the Lift Caddy installed you can effortlessly roll that job out and roll in your next job. Install the "Lift Caddy" in less time than it takes to change oil.

Your Lift Caddy is supplied with 2 heavy duty casters that can turn 360 degrees and a mounting stand capable of handling heavy weight motorcycles. All for the same money you would be spending for a good steak dinner with wine for two. You could have installed a Lift Caddy on your bike lifts.

Use on all bike lifts that have a 2" square bottom cross member with 15" of mounting room on the cross member. Will fit on Handy® lifts like Handy's® STANDARD No. 10740, and Direct Lifts.



**NOTE: PLEASE READ ALL INSTRUCTIONS COMPLETELY BEFORE PERFORMING ANY WORK!
IF YOU DO NOT KNOW WHAT YOU ARE DOING, DO NOT DO IT!**

No information in this instruction sheet pertaining to motorcycle repair is represented as foolproof or even altogether safe. Even something safe, done incorrectly or incompletely can and will backfire. You and only you are responsible for the safety of your repair work and for you understanding the application and use of repair equipment, components, methods and concepts.

Each and every step this tool is designed to do must be carefully and systematically performed safely by you. All information listed in this instruction sheet has been tested, re-tested and used daily in JIMS® Research and Development Department.

ALWAYS WEAR SAFETY GLASSES OR OTHER FACE AND EYE PROTECTION SUCH AS FULL FACE SHIELD. JIMS® IS NOT RESPONSIBLE FOR DAMAGE, INJURY, OR YOUR WORK. JIMS® IS NOT RESPONSIBLE FOR THE QUALITY AND SAFETY OF YOUR WORK.

PARTS AVAILABLE SEPARATELY			
No.	Qty.	Description	Part No.
1	2	CASTER MOUNTS	776-1
2	1	FRAME MOUNT	776-2
3	1	STICKER (NOT SHOWN)	776-3
4	2	CASTER	2101
5	8	SCREW	2103
6	2	WASHER	2038
7	2	NUT	1027
8	1	INSTRUCTION SHEET	776-IS

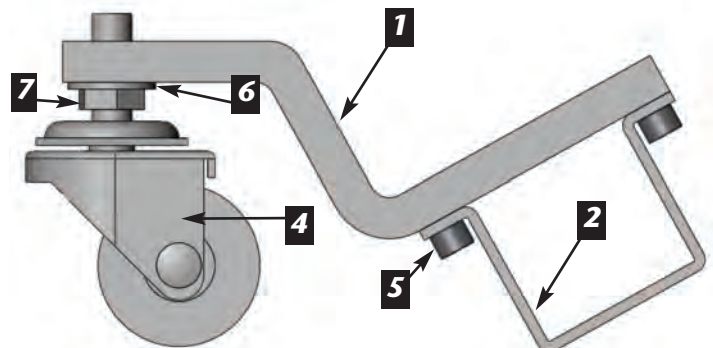

Performance Parts For Harley-Davidson Motorcycles

555 DAWSON DRIVE, CAMARILLO, CA 93012 PHONE 805-482-6913 • FAX 805-482-9224
VISIT US ON THE WEB AT WWW.JIMSUSA.COM



A Division of Thiessen Products, Inc.

INSTRUCTION SHEET FOR TOOL No. 776

TOOLS RECOMMENDED FOR USE WITH THIS TOOL:

- 1/4" Allen wrench or Allen socket, for installing Lift Caddy mount to bike lift
- Two 3/4" open end wrenches to adjust and lock nut on caster studs
- 2 Jack stands, to hold lift up while installing Lift Caddy
- Tape measure or calipers to help center Lift Caddy
- Safety glasses to protect your eyes

Warning: Do not install Lift Caddy with motorcycle on bike lift. You will be installing the Lift Caddy to the bottom rear foot of bike lift. The bike lift should be on a smooth and flat floor.

1. Raise bike lift all the way up. Do not fold down the height locking bar. Place one jack stand under each side of lift table. Slowly let out air (as to lower bike lift). This will raise the rear foot of the bike lift. Allow it to rise off the floor about 12" or at a comfortable height. If necessary block up the foot to keep it off the ground. Remove the air supply if needed. **See Fig 1.**



FIG. 1

2. Apply a small amount of clean oil to the threads of all 8 mounting bolts No. 2103.
3. Place the Frame mount No. 776-2 under the cross bar. Center it so there is approximately 2-1/2" on either side.

See Fig 2.

Note: You should have the same dimension on each side of main mount.

4. Place one caster mount No. 776-1 over the top of frame mount No. 776-2. with the mount lip cutout area facing the front of the lift as shown. Certain lifts require this clearance. Align it with the 4 mounting holes and thread in all 4 screws No. 2103. Do the same with the other caster mount. Torque bolts in a criss-cross pattern to 15 ft-lb. **See Fig 3.**

5. Apply a small amount of oil to threads of both threaded caster mounting studs No. 2101. Thread each lock nut No. 1027 on to each caster stud. Thread nuts all the way down caster mounting studs, then place each washer No. 2038 over caster studs. Thread each caster stud into the bottom side of caster mount. Do this by hand until it stops at lock nut.

See Fig 4.

6. Remove any of the blocks used to keep foot off the ground.
7. If air supply had been removed reinstall it. Slowly apply air to push rear foot back to the floor (ground). This will also lift the table off the jack stands. Remove jack stands and fold down height locking bar. Let all air out of bike lift to allow height locking bar to lock

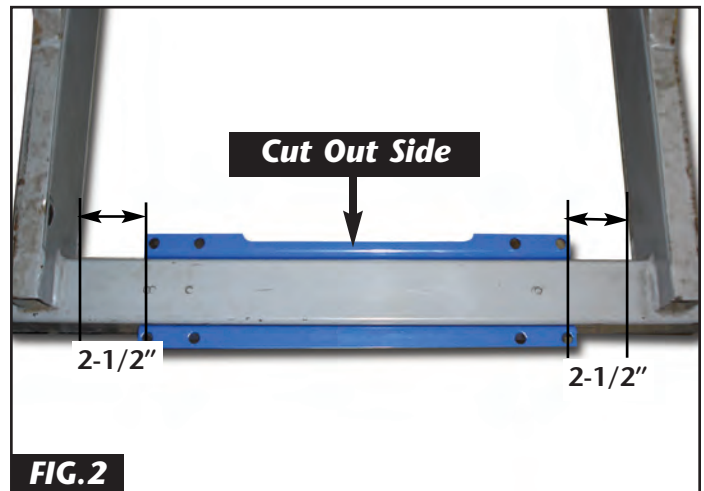

FIG. 2

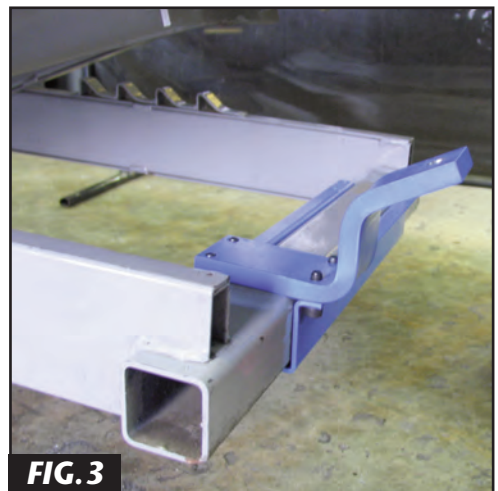

FIG. 3

Performance Parts For Harley-Davidson Motorcycles

555 DAWSON DRIVE, CAMARILLO, CA 93012 PHONE 805-482-6913 • FAX 805-482-9224
VISIT US ON THE WEB AT WWW.JIMSUSA.COM



A Division of Thiessen Products, Inc.

INSTRUCTION SHEET FOR TOOL No. 776

into the highest position. Place warning sticker No.776-3 on the cross bar of bike lift as shown. **See Fig 5.**

8. With your 3/4" wrench, turn lower caster nut out. This will move caster down to the floor. Stop turning caster stud out just as caster wheels make contact with floor. **See Fig 6.**

Note: Make sure caster wheels can turn by hand, just touching the floor, 360 degrees.

9. Turn locknut No. 1027 on caster stud up until it is making contact with underside of caster mount No.776-2. Tighten lock nut to about 20 ft-lb of torque with two 3/4" wrenches. **See Fig 7.**

10. Raise bike lift to its highest point. At this point both caster wheels should be pushed to the floor, lifting the rear of bike lift by approximately 1/4". **See Fig 8.**

Note: The highest point will place the fold down height locking bar about 1.500" above its highest lock tab. With your bike lift in this position, it will allow you to move the bike lift around the shop floor with or without a bike installed.

11. Test caster height adjustment by rolling the Bike Lift around, if you prefer to have more or less caster wheel engagement repeat lines 8, 9, and 10 until you are satisfied with the movement of lift.

Note: Check hardware torque after using bike lift a few times.

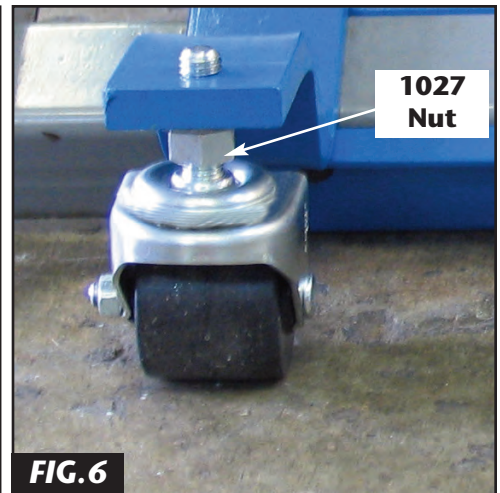
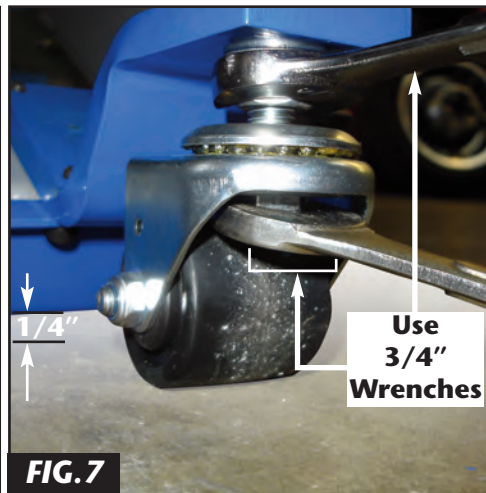
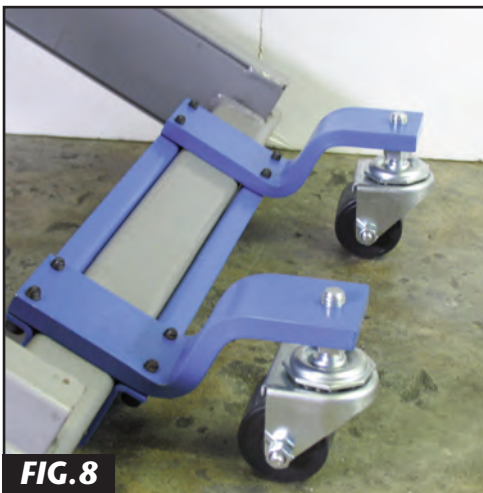
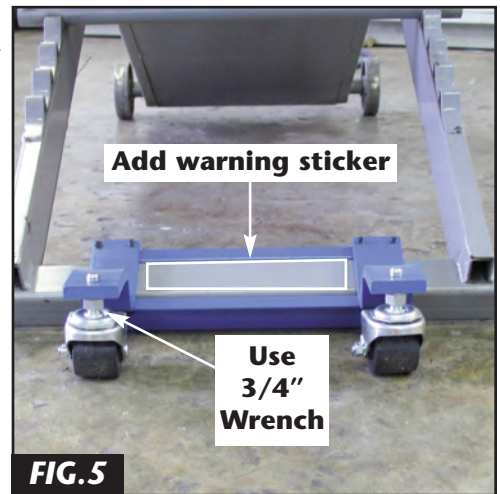
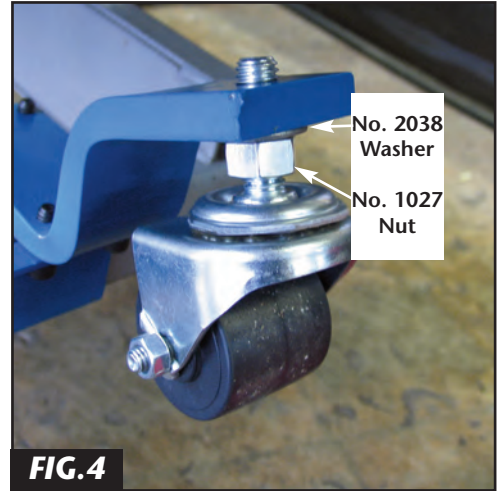

Performance Parts For Harley-Davidson Motorcycles

555 DAWSON DRIVE, CAMARILLO, CA 93012 PHONE 805-482-6913 • FAX 805-482-9224
VISIT US ON THE WEB AT WWW.JIMSUSA.COM