

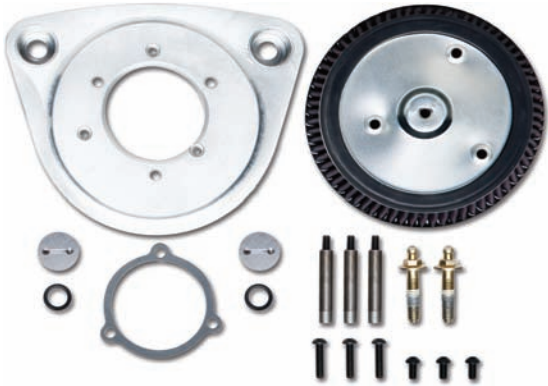

A Division of Thiessen Products, Inc.

**INSTRUCTION SHEET FOR No. 5275, 5285, 5286, 5287, 5288, & 5276**

**AIR CLEANER BACKING PLATE KIT**



No. 5275 Black, No. 5286 Chrome - Use on JIMS® 53mm, 58mm, & 62mm Elliptical Throttle Bodies and Screamin' Eagle Pro Super Bore 51mm CV Carburetor No. 27928-07.

No. 5276 Black, No. 5287 Chrome- Use on all 2008- Present stock H-D throttle body – electronic throttle (fly by wire) also fits Screamin' Eagle Pro High Flow 58mm EFI throttle Screamin' Eagle Pro High Flow 58mm EFI throttle body No.27713-08 and Screamin' Eagle Pro High Flow 58mm EFI throttle body – cable operated throttle No.27639-07.

No. 5285 Black, No. 5288 Chrome- Use on 00-later Softail 99-07, Touring models (except 99-01 EFI models), and 99-07 Dyna models. Also use on 08-later Dyna models with original equipment CV, Screamin' Eagle CV (except CV 51mm Super Bore), and flatslide carburetors. Use on 06-09 CVO Electra Glide, 09 CVO Road King, 09 CVO Road Glide, 08-09 CVO Springer Softail and 09 CVO Dyna models with separate purchase of air cleaner cover H-D No. 29121-07 or accessory air cleaner, stock on 05 15th anniversary FLSTF, 05-07 CVO Softail, 07-08 CVO Dyna and 07 CVO Road King models.

**FOR RACE APPLICATION ONLY.**

**NOTE: USE JIMS NO. 1170 TOOL FOR DRIVING NO. 5278-1 AND 5278-2 PLUGS. TOOL SOLD SEPARATELY.** Read complete instructions thoroughly before assembling or using this air cleaner kit. Refer to the last two pages of these instruction sheets for a blowup view of complete for installation and part number reference.

**NOTE: IF YOU DO NOT KNOW WHAT YOU ARE DOING, DO NOT DO IT! ALWAYS WEAR SAFETY GLASSES OR OTHER FACE AND EYE PROTECTION SUCH AS FULL FACE SHIELD. JIMS® IS NOT RESPONSIBLE FOR DAMAGE, INJURY, YOUR WORK, OR THE QUALITY AND SAFETY OF YOUR WORK.**

**PARTS AVAILABLE SEPARATELY**

No.	Qty.	Description	Part No.
1	3	SCREW, 1/4-20 X 1/2", BHCS, BLK, AIR ELEMENT	8090
2	1	AIR ELEMENT (H-D® #29244-08 OR K&N #HD-0818)	5277
3	3	STANDOFF, FILTER	5279
4	2	PLUG, BLACK BACKING PLATE	5278-1
5	2	BOLT, BREATHER, VENTED	5283
6	1	BACKING PLATE, BLACK, JIMS EFI	5281 & 5280
7	1	BACKING PLATE, BLACK, HD EFI	5282 & 5280
8	1	BACKING PLATE, BLACK, STOCK DELPHI EFI	5284 & 5280
9	1	BACKING PLATE ASSY, CHROME, JIMS EFI	5289
10	1	BACKING PLATE ASSY, CHROME, 58MM EFI BY WIRE	5290
11	1	BACKING PLATE ASSY, CHROME, STOCK DELPHI	5291
12	1	GASKET, BACKING PLATE, JIMS EFI	876
13	3	SCREW, 1/4-20 X 1 1/4", BHCS, BLK, BACKING PLATE	2166
14	2	O-RING, BREATHER STANDOFF	874
15	1	GASKET, BACKING PLATE, HD 58MM BY WIRE EFI	875
16	1	GASKET, BACKING PLATE, FOR STOCK DELPHI	884
17	1	PLUG, CHROME, BACKING PLATE	5278-2
18	1	INSTRUCTION SHEET	5275-IS

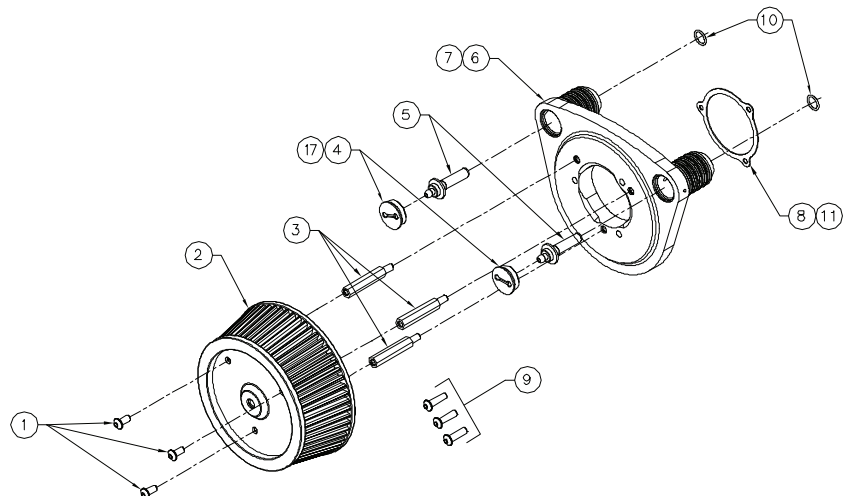

*Performance Parts For Harley-Davidson Motorcycles*

555 DAWSON DRIVE, CAMARILLO, CA 93012 PHONE 805-482-6913 • FAX 805-482-9224  
VISIT US ON THE WEB AT WWW.JIMSUSA.COM



A Division of Thiessen Products, Inc.

## INSTRUCTION SHEET FOR No. 5275, 5285, 5286, 5287, 5288, & 5276

### Special Tools Needed:

1. Tuning software for year and model motorcycle this air filter kit will be installed on.
2. A fire extinguisher that is capable of putting out a gas fire.
3. H-D® service manual, or equivalent, for the motorcycle you will be repairing.
4. Assembly lube.
5. Blue Loctite, used on all mounting hardware.
6. Torque wrench 3/8" drive, in-lbs
7. Torque wrench 3/8" drive, ft-lbs
8. 3/8" drive 7/16" deep socket.
9. 5/32" Allen head socket 3/8" drive.
10. 3/4" socket, 3/8" drive, to torque backing plate plugs No. 5278-1 or -2 with JIMS tool No. 1170.
11. JIMS tool No. 1170 for tightening No. 5278-1, No. 5278-2 backing plate plugs.

See JIMS® catalog for hundreds of top quality professional tools.

**WARNING:** WORKING WITH GASOLINE IS VERY DANGEROUS AND HIGHLY EXPLOSIVE. WHEN YOU'RE WORKING ON THE FUEL SYSTEM DON'T SMOKE OR HAVE ANY SPARKS OR OPEN FLAMES ANYWHERE NEAR YOUR SERVICE AREA. THIS INCLUDES GAS FIRED WATER HEATERS. YOUR LIFE DEPENDS ON THE SAFETY PRECAUTIONS YOU TAKE. NON-SUFFICIENT SAFETY PRECAUTIONS COULD RESULT IN DEATH OR SERIOUS INJURY. ALWAYS WEAR SAFETY GLASSES, OR FULL FACE SHIELD, OVER YOUR EYES AND FACE. EXCESSIVE FORCE MAY CAUSE DAMAGE TO PARTS OR YOURSELF.

**JIMS® IS NOT RESPONSIBLE FOR THE QUALITY, SAFETY, DAMAGE, OR INJURIES FROM YOUR WORK.**

**WARNING:** If any fuel is spilled, wipe up immediately. Excess fuel needs to be contained in a suitable manner. Wear safety glasses over your eyes. If any fuel gets on any part of your body wash it off.

**WARNING:** Disconnect the battery ground cable from the battery.

- A. Follow your H-D service manual for removal of stock air filter assembly.
- B. Install both O-rings No. 874 to the back side of both breather housings of air cleaner backing plate. Use a small amount of gasket sealer to hold o-ring in place if required. **See Fig 1**
- C. Place the backing plate gasket No. 875 for use on H-D throttle body or No. 876 for use on JIMS throttle body onto back side of plate (side that mount against throttle body). Apply a small amount of gasket sealer on gasket and then position gasket to align with the three mounting holes on backing plate. Insert three No. 2166 screws from the air element side on backing plate. Hold backing plate in the palm of your hand and keeping screws in position. Apply two drops of blue Loctite to each screw. Now install on mounting surface of the throttle body, just snug at this time with your 5/32 allen socket. **See Fig 2**
- D. Apply 3 drops of blue Loctite to the first few threads of both breather bolts, No. 5283. Install bolts through backing plate's breather housings, just snug at this time with your 7/16" socket. **See Fig 3.**



*Performance Parts For Harley-Davidson Motorcycles*

555 DAWSON DRIVE, CAMARILLO, CA 93012 PHONE 805-482-6913 • FAX 805-482-9224  
VISIT US ON THE WEB AT WWW.JIMSUSA.COM

## INSTRUCTION SHEET FOR No. 5275, 5285, 5286, 5287, 5288, & 5276

**Note:** It may be necessary to move the throttle body (with backing plate) up or down a very small amount to align the bolts with the bolt holes in both heads. This may require just loosening the intake clamps on the manifold.

- E. Torque the three screws from line **C** to 60 in-lbs in a criss - cross pattern.
- F. Torque both bolts from line **D** to 15 ft-lbs, first one side, then the other, then torque both to 24 ft-lbs.
- G. Install all three standoffs, No. **5279**. Apply two drops of blue Loctite to the first few threads. With your 3/8" socket, torque all to 60 in-lbs in a criss - cross pattern.

**See Fig 4**

- H. Install both screw plugs No. **5278-1** or **-2**. Apply two drops of blue Loctite to the first few threads, torque each cover with either JIMS tool No. **1170** to 60 in-lbs **See Fig 5**

- I. Place air filter element No. **5277**, over the 3 standoffs. Align all 3 holes with the 3 holes on the element plate end of each standoff. Notice that one mounting hole is closer to element centerline and locate this hole at the six o'clock position as shown.

**See Fig 6.**

- J. Apply 2 small drops of blue Loctite to the threads of all three No. **8090** screws and torque with your 5/32" Allen socket to 60 in-lbs. **See Fig 7.**
- K. Install your outer air cleaner cover and tune as required. **See Fig 8.**



FIG. 2

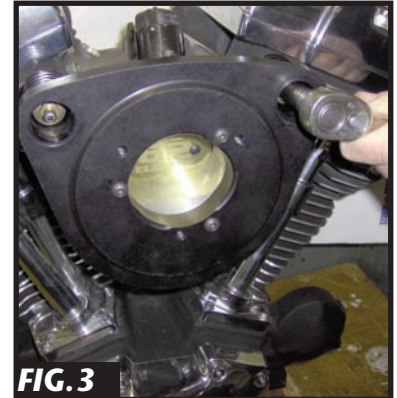

FIG. 3

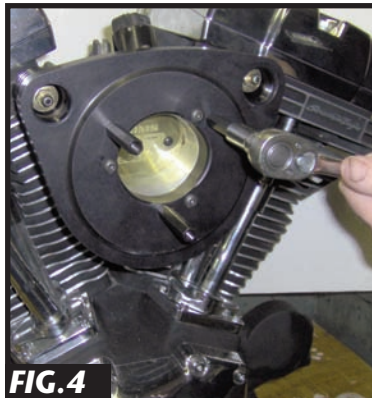

FIG. 4



FIG. 5



FIG. 6

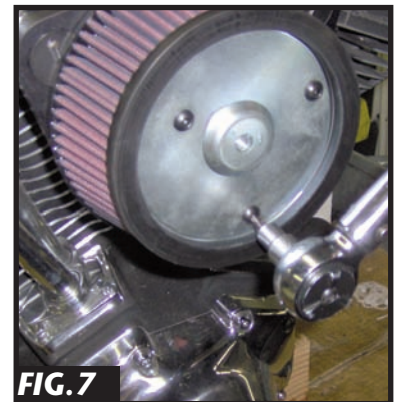

FIG. 7

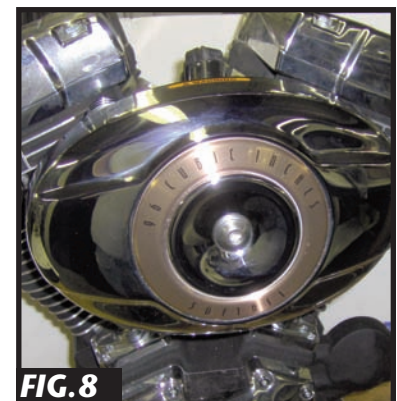

FIG. 8

*Performance Parts For Harley-Davidson Motorcycles*

555 DAWSON DRIVE, CAMARILLO, CA 93012 PHONE 805-482-6913 • FAX 805-482-9224

VISIT US ON THE WEB AT WWW.JIMSUSA.COM