

INSTRUCTION SHEET FOR TOOL No.2260

SPROCKET LOCKER TOOL

FOR ALL BIG TWIN 1980 TO PRESENT, H-D OR AFTERMARKET TRANSMISSION PULLEYS INCLUDING H-D 6-SPEED CRUISE DRIVE

Use to remove all final drive belt sprockets on Big Twins.

CAUTION: Nut is a left hand thread on 5-speed. 6-speed Cruise Drive has right hand threads.

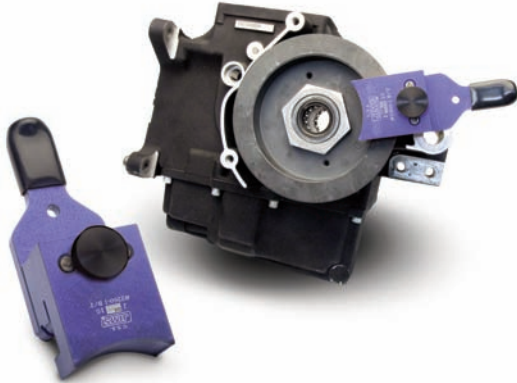

1. Refer to H-D® Service Manual for specifications.
2. To remove nut, attach tool to sprocket and place handle of tool on top of the pivot shaft, inboard of the bottom frame tube. On Cruise Drive, contact bottom of pivot shaft.
3. Snug up the thumb screw to hold tool position on the sprocket.
4. When tightening nut, the handle of the tool will contact bottom of pivot shaft on 5-speeds. For Cruise Drive 6-speed, handle should contact the top of pivot shaft. Tighten to H-D® specifications using JIMS® Sprocket Nut Tool No.94660-37A for and 5-speeds, or JIMS No.989 for any H-D 6-speed Cruise Drive transmissions.

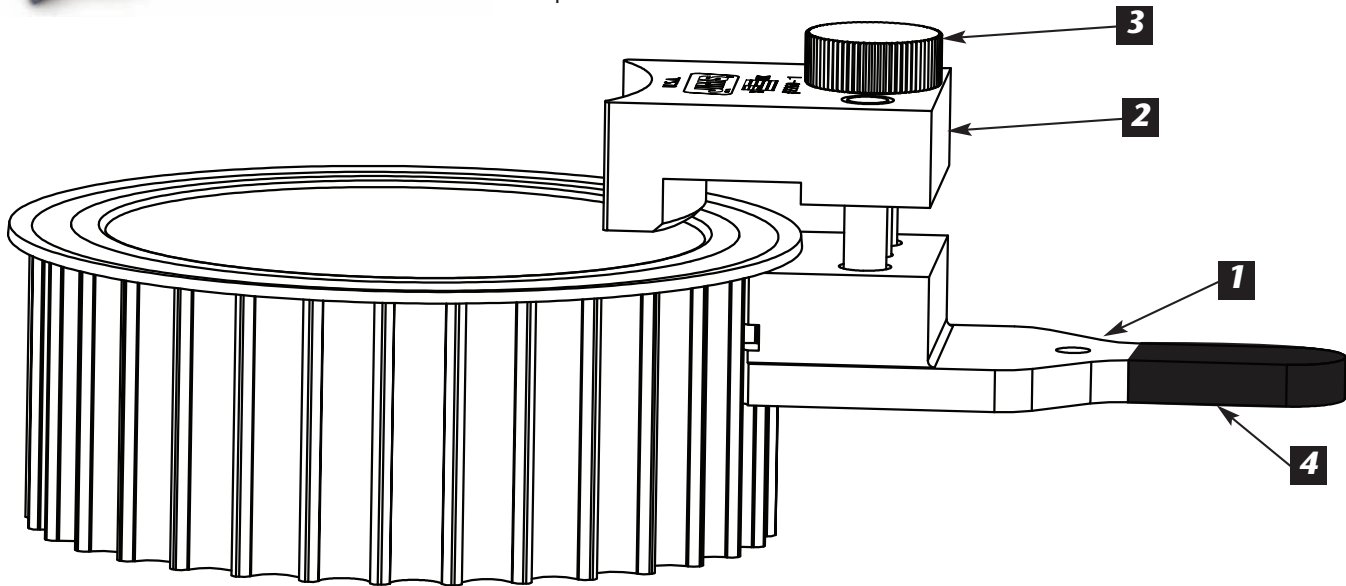

PARTS AVAILABLE SEPARATELY

NO.	QTY.	DESCRIPTION	PART NO.
1	1	TOOL, LOCKING TOP	2260-2
2	1	TOOL, LOCKING BOTTOM W/ DOWELS	2259-2
3	1	THUMB SCREW	1396
4	1	CAP	2321
5	1	INSTRUCTION SHEET	2260-IS

CAUTION: WEAR SAFETY GLASSES. EXCESSIVE FORCE MAY DAMAGE PARTS AND TOOLS! SEE JIMS® CATALOG FOR OVER 100 OTHER TOP QUALITY PROFESSIONAL TOOLS. THE LAST TOOLS YOU WILL EVER NEED TO BUY.

"From the Track... To the Street!"

555 DAWSON DRIVE, CAMARILLO, CA 93012 • PHONE 805-482-6913 • FAX 805-482-9224

VISIT US ON THE WEB AT WWW.JIMSUSA.COM