



A Division of Thiessen Products, Inc.

INSTRUCTION SHEET FOR TOOL #1672

CRANKCASE BEARING REMOVER AND INSTALLER 2003-PRESENT

Use on Twin Cam 2003-Present "Alpha" engines, pinion and sprocket side, main case bearing.

Use on Twin Cam 2003-Present "Beta" (Softail) engines, sprocket side, main case bearing.

**NOTE: PLEASE READ ALL INSTRUCTIONS COMPLETELY BEFORE PERFORMING ANY WORK!
IF YOU DO NOT KNOW WHAT YOU ARE DOING, DO NOT DO IT!**

No information in this instruction sheet pertaining to motorcycle repair is represented as foolproof or even altogether safe. Even something safe, done incorrectly or incompletely can and will backfire. You and only you are responsible for the safety of your repair work and for understanding the application and use of repair equipment, components, methods and concepts.

Each and every step this tool is designed to do must be carefully and systematically performed safely by you. All information listed in this instruction sheet has been tested, re-tested and used daily in JIMS® Research and Development Department.

ALWAYS WEAR SAFETY GLASSES OR OTHER FACE AND EYE PROTECTION SUCH AS FULL FACE SHIELD. JIMS® IS NOT RESPONSIBLE FOR DAMAGE, INJURY, OR YOUR WORK. JIMS® IS NOT RESPONSIBLE FOR THE QUALITY AND SAFETY OF YOUR WORK.

CAUTION: Wear safety glasses. Excessive force may damage parts and tool.

Note: Please read all instructions completely and thoroughly before performing any work.

Recommended JIMS tools

See JIMS catalog for a complete list of engine tools. Catalog may be viewed at www.jimsusa.com

Other Recommended tools and parts:

- Service manual for the year and model you will repairing.
- Parts book for the year and model you will repairing.
- New bearings
- New retaining rings (2003 – 2010)
- New retaining screws (2011 to present)
- Retaining ring remover
- Clean engine oil
- Tools to check bearing bores

Read complete instructions thoroughly before using this tool

Refer to H-D Service Manuals, for the year and model your working on, to prep engine cases for usage of this tool.

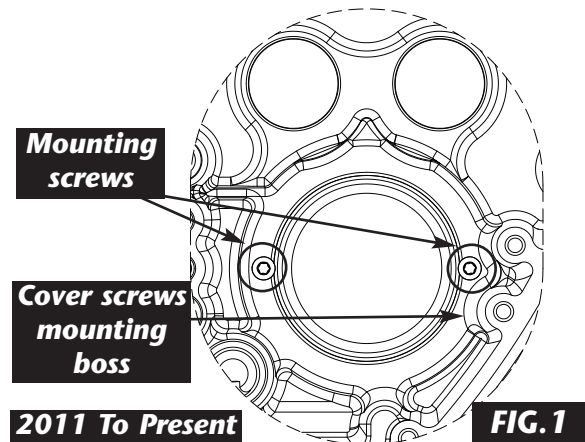

Right Case Bearing Removal: For 2011 to present Alpha Only engines

1. Start by removing and discarding 2-case bearing retaining screws from cam chest area **See Fig 1**
2. Take support tube No. **1670** and place it on a clean hydraulic press table with the laser marked "A" side of tool facing upward.
3. Next place the right case with the cam chest side facing downward on the support plate. On the 2011 and later models you will need to position the No. **1670** tool with the small half circle cutout on the top edge to locate in the cam chest area to clear the screw mounting boss and sit flush against the bearing.

See Fig 2

Performance Parts For Harley-Davidson Motorcycles

INSTRUCTION SHEET FOR TOOL #1672

4. Now lightly lube and slide the small end of the driver / pilot No.1671 through the I.D. of the bearing and into the support tube. **See Fig 2**
5. Center the pilot / driver No.1671 under the ram of the press. Apply pressure until the bearing is free. Discard bearing. **See Fig 2**

Right Case Bearing Removal: For 2003 to 2010 Alpha Only

1. Take support tube No.1670 and place it on a clean hydraulic press table with the laser marked "A" side of tool facing upward. **See Fig 3.**
2. Next place the right case with the cam chest side facing upward and position the bearing over the support tube No.1670 with A side up. **See Fig 3**
3. Now lightly lube and slide the small end of the driver / pilot No.1671 through the I.D. of the bearing and into the support tube. **See Fig 3**
4. Center the pilot / driver under the ram of the press. Apply pressure until the bearing is free. Discard bearing. **See Fig 3**

Right Case Bearing Installation: 2003 Alpha models to present

1. Inspect and clean bearing bore. Next take your new bearing and apply a light coating of motor oil to the O. D. of the bearing. Also lube the bearing case bore surface.
2. Turn over the support No.1670 with the "B" laser marked side facing upward on a clean hydraulic press table. **See Fig 4**
3. Place the right case half with the cam chest facing upward and position bearing bore on the support tube No.1670 with the "B" side end upward. **See Fig 4**
4. Next place the lubed small end of No.1671 pilot / driver into the lubed I.D. of the bearing and position over bearing bore. You also need to lube the leading edge of the bearing before pressing into case. Note, that the bearing letters should face the tool when you slide on the pilot tool **See Fig 4**
5. Center pilot / driver No.1671 under the press ram. Apply pressure to pilot /driver until resistance is felt and bearing is bottomed on the support tube. **See Fig 4**
6. Remove pilot / driver and right case half from support tube.

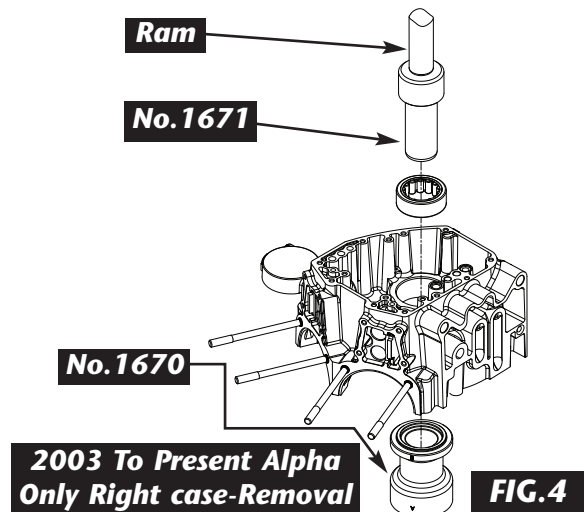
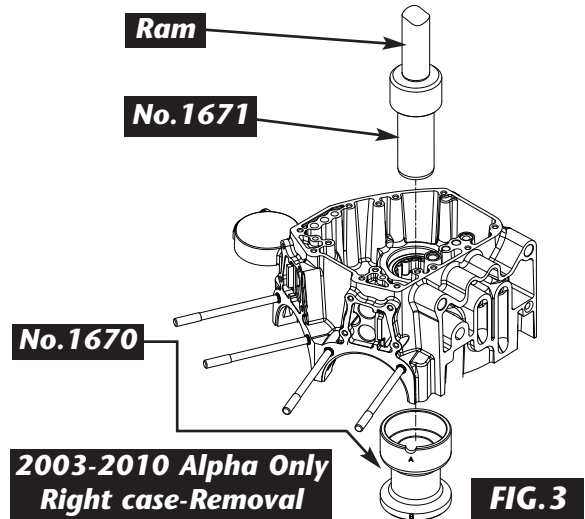
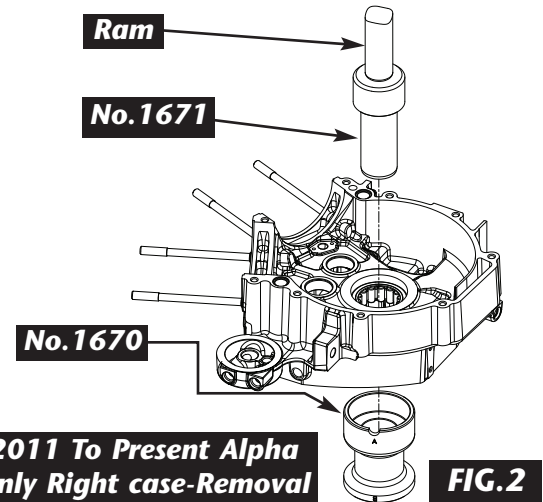

INSTRUCTION SHEET FOR TOOL #1672

Note: For 2011 to present Alpha models only:

- Verify that the case bearing is flush or slightly below the crankcase. Never push the bearing into position using the retaining screws. If new screws are not available, apply Loctite Threadlocker 243 (blue) to the threads before installation.

See Fig 1

- Install two new main bearing retaining screws from the cam chest side and torque to 40 -70 in lbs. (4.5-7.9 Nm) **See Fig 1**

Left Case Bearing Removal: 2003 to present, Alpha and Beta Twin Cam

- Remove from the outer case oil seal H-D No.12068 and discard.
- Always wear safety glasses when working with retaining rings. Remove from the inner case side the retaining ring using a small flat blade screwdriver. Use the tip of the screwdriver to carefully lift the edge of the retaining ring up and out of its groove in the case. Be careful not to damage the lip of the groove in the case.

See Fig 5

Note: If the ram of your press is wider than the head of No. 1671 pilot / driver tool then a suitable press plug will be needed in order to remove the case bearing.

- Place the support tube No. 1670 with the lasered "A" end of tool facing upward on the hydraulic press table. **See Fig 6**
- Place the left case half with the outer case side facing upward and position and locate on the bearing over the support tube.
- Slide Pilot / Driver No.1671 through bearing to be removed and into support tube. **See Fig 6**
- See Note: above.
- Center pilot / driver No. 1671 under the press ram and apply pressure until bearing is free **See Fig 6**
- Remove case half, pilot / driver, and discard old bearing.

Left Case Bearing Installation: 2003 to present, Alpha and Beta Twin Cam

- Inspect and clean bearing bore and retaining ring groove. Next take your new bearing and apply a light coating of motor oil to the O. D. of the bearing. Also lube the bearing case bore surface.
- Place the support No.1670 with the "A" laser marked side facing upward on a clean hydraulic press table. **See Fig 7**
- Place the left case half with the inner case half facing upward and

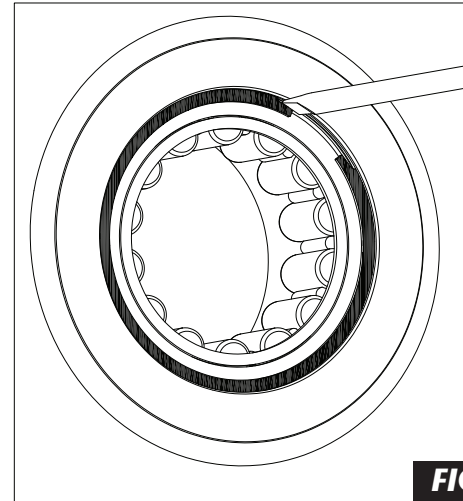

FIG.5

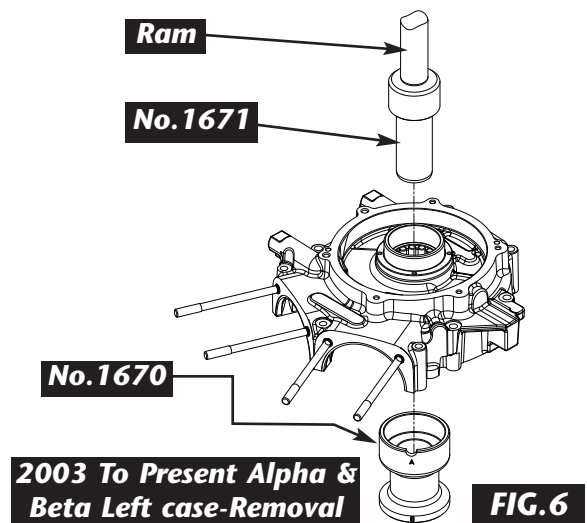

FIG.6

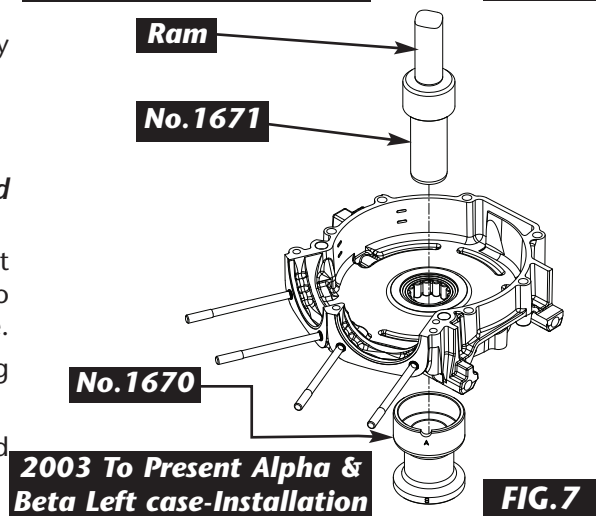

FIG.7

Performance Parts For Harley-Davidson Motorcycles



A Division of Thiessen Products, Inc.

INSTRUCTION SHEET FOR TOOL #1672

position bearing bore on the support tube No.1670 with the "A" side end upward. **See Fig 7**

4. Next place the lubed small end of No.1671 pilot / driver into the lubed I.D. of the bearing and position over bearing bore. You also need to lube the leading edge of bearing before pressing into case. Note that the bearing letters should face the tool when sliding on the pilot tool. **See Fig 7**
5. Center pilot / driver under the press ram . Apply pressure to pilot /driver until bearing is lightly bottomed in main case bore.
See Fig 7
6. Remove pilot / driver and left case half from support tube.
7. Always wear safety glasses when working with retaining rings. Install new bearing retaining ring into inner left case half bore groove. Work retaining ring into groove, being careful not to damage edges of groove. Make sure retaining ring is fully seated.

Note: *If retaining ring will not fit into groove in the bearing bore, it's possible the bearing is not fully seated in the bore . Examine the bearing and bore. If necessary, remove the bearing, clean bore and install bearing and then the retaining ring.*

CAUTION: WEAR SAFETY GLASSES OVER YOUR EYE'S.
SEE JIMS® CATALOG FOR HUNDREDS OF TOP QUALITY PROFESSIONAL TOOLS.
THE LAST TOOLS YOU WILL EVER NEED TO BUY.

Performance Parts For Harley-Davidson Motorcycles