

## Congratulations

You and your Harley® have just taken the first steps towards owning the finest precision designed and engineered valve train components known to the Harley-Davidson® market. JIMS® tappets, tappet blocks and cam covers surpass the stock requirements and demands of the present and future Harley-Davidson® motorcycle.

To achieve the best life possible from this tappet (or any other valve train part) you must be aware of some very important issues.

1. Clean! Clean! Clean! You must use the best possible oil and oil filter available for your Harley-Davidson®. Use only motorcycle or air cooled type engine oil. No Substitutes!
2. If these tappets are being installed in a motor that has had motor problems, or was rebuilt, wash out oil tank, oil feed lines and motor.
3. If these tappets are replacing a previous tappet and cam problem, please make sure you know what caused the problem in the first place.
4. The first area of concern is that the tappet roller must seat flat on cam. JIMS® tappets are square from the tappet body to the axle bore within .0002". If the roller is not seated flat on the cam, it will fail within a short period of time.
5. Second concern: The same holds true for the tappet blocks. JIMS® tappet blocks are machined to hold the bores perpendicular to the mounting flange within  $\pm .0002$  of an inch.
6. The next important concern is alignment of the cam itself. First, the cam will be, or should be, parallel from the two bearing journals to the lobes within  $\pm .0002$ , (this is just the cam). With the cam installed in the motor this can be a lot different. For this reason, JIMS® has a precision machined cam cover to hold your cam to within .0002" of cam centerline.

As you can see from some of the examples there are a lot of possible reasons for your valve train to have a shortened life. For this reason JIMS® is continuously helping you achieve the longest possible life for your valve train.

### WARRANTY

All JIMS® parts are guaranteed to the original purchaser to be free of manufacturing defects in materials and workmanship for a period of six (6) months from the date of purchase. Merchandise that fails to conform to these conditions will be repaired or replaced at JIMS® option if the parts are returned to us by the dealer (purchaser) within the six (6) month warranty period or within ten (10) days thereafter.

In the event warranty service is required, the original purchaser must call or write JIMS® immediately with the problem. Some problems can be rectified by a telephone call and need no further course of action. A part suspected of being defective must not be replaced by a dealer without prior authorization from JIMS®. If it is deemed necessary for JIMS® to make an evaluation to determine whether the part is defective, it must be packaged properly to prevent further damage and be returned prepaid to JIMS® with a copy of the original invoice of purchase and a detailed letter outlining the nature of the problem, how the part was used and the circumstances at the time of failure. If after an evaluation has been made by JIMS® and the part was found to be defective, repair, replacement or credit will be granted.

### ADDITIONAL WARRANTY PROVISIONS

- 1.) JIMS® shall have no obligation in the event a JIMS® part is modified by any other person or organization.
- 2.) JIMS® shall have no obligation if a JIMS® part becomes defective in whole or in part as a result of improper installation, improper maintenance, improper use, abnormal operation, or any other misuse or mistreatment of the part.
- 3.) JIMS® shall not be liable for any consequential or incidental damages resulting from the failure of a JIMS® part, the breach of any warranties, the failure to deliver, delay in delivery, delivery in nonconforming condition, or for any other breach of contract or duty between JIMS® and a customer.
- 4.) JIMS® parts are designed exclusively for use in Harley-Davidson® Motorcycles. JIMS® shall have no warranty or liability obligation if a JIMS® part is used in any other application.

***"From The Track... To The Street!"***

# FOUR POSSIBLE REASONS THAT MAY KEEP NEW HYDRAULIC UNITS FROM WORKING PROPERLY

IMPROPER FIT • MECHANICAL • CONTAMINATION OF OIL SUPPLY • LOW OIL SUPPLY

## 1. IMPROPER FIT

- Not likely, each unit goes through (2) two tests.
- First the fit is checked twice, .00015" to .0002".
- Second, a hydraulic bleed down test is performed first dry, then with 5 weight oil.

## 2. MECHANICAL

- Not adjusted properly, readjust per instruction sheet. For 2456-1, 18526-PG and 2459-1, the hydraulic unit itself needs to be at .100 ± .010 below snap ring. For 1029-53 kit the hydraulic unit itself needs to be .050 ± .010 below the snap ring. Some shovel models from 1978-1980 have tappet blocks with oil drain holes to low. If running a higher lift cam then stock, and sometime even stock, these blocks will allow oil pressure to bleed off from the tappets, this is most common in the front tappet block.
- A bent pushrod, loose valve guides, broken valve spring, valve hitting piston, valve hitting valve, rocker bushing loose, rocker tip wear at valve stem, and lifter roller hitting tappet block. All will cause a noisy valve train.
- Gear lash: if you did not change the cam at the time you installed new hydraulic units and had no gear lash, but a slight whine motor when motor was cold, it is safe to say you are OK in this area.
- Hydraulic valve spring broke, is not allowing valve to seal. We have not seen this on any JIMS® hydraulic units.
- If this is the case the hydraulic unit will not hold oil pressure, to check this hold pushrod with your hand (with lifter on the heel of cam valve shout) push down on pushrod. Hydraulic unit will feel spongy. Do not mistake this for no oil getting to tappet. If all tappets are spongy this is no oil. If just one tappet is spongy and has been readjusted, and still will not pump up, replace tappet.

## 3. CONTAMINATION OF OIL

- Hydraulic unit may work for a minute and then become noisy, most of the time it is more then one hydraulic unit that will be contaminated to the point of being stuck in the downward position.
- Readjust per instruction sheet. If hydraulic unit will not come back up to the top of snap ring, replace hydraulic unit and wash out the entire oil system.

## 4. OIL PRESSURE AT NORMAL OPERATING TEMPERATURE, AT ABOUT 2,000 R.P.M., SHOULD BE 12-35 P.S.I..

- Check lifter filter screen. ( Big Twin )
- Make sure your getting oil to the lifters. Install oil pressure gauge for top end oil.
- Lifter to tappet block clearance is best at .0007"-.0012".
- Lifters work best with 20w-50w motorcycle oil.
- If lifters are quiet when cold or low r.p.m., and become noisy as r.p.m. is increased, there is not enough oil pressure or to much clearance from lifter to block bore. (see "C")
- To isolate a possible noisy hydraulic lifter start with a cool motor and the lifter you think is making the noise. With that lifter on the heel of cam, valve shut, adjust pushrod so lifter unit is all the way compressed down ( very important ) this adjustment will make the pushrod tight which will bleed down the hydraulic lifter. It will sometimes take (5) five minutes, or longer, to bleed down. Do not rotate engine while pushrods are tight. Go to the point where pushrod will spin with your fingers. Adjust down a little more until pushrod becomes tight ( you can just barely turn with your fingers ). Start bike, if it is quiet then you have found the lifter that was not working properly. If it's still noisy continue with the next lifter until you have located the the noisy one. Readjust per instruction sheet, or replace lifter.

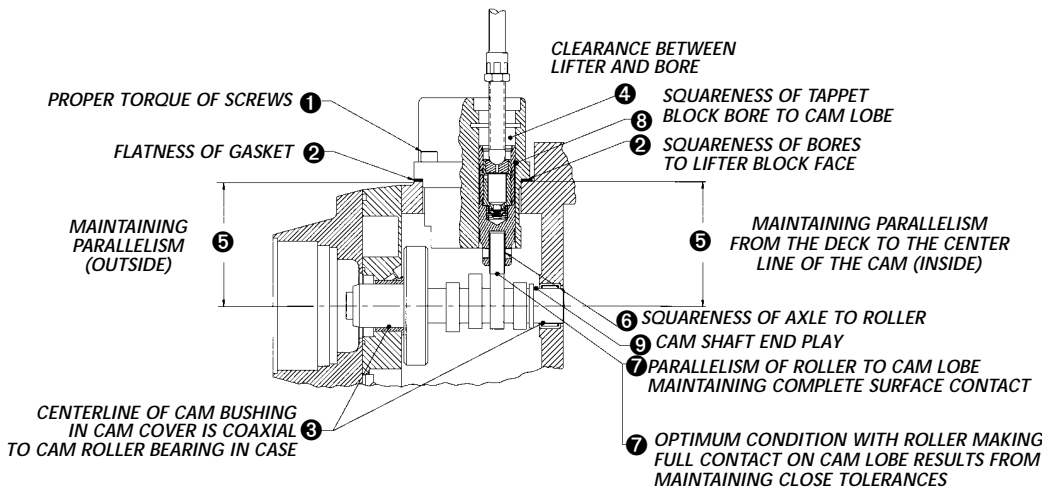

Pushrod Adjustments				
Distance per turn	Distance per flat	Threads per inch	Wrench Flats	Total Travel Distance
.0417	.0069	24	15	.1042"
.0357	.0059	28	17	.1011"
.0313	.0052	32	18	.0937"
.025	.0042	40	24	.100"
.0192	.0032	52	30	.0962"

Popular Pushrods		
JIMS®	24	Pro-Lite (Evo Big Twin)
JIMS®	32	Slim-Jims (Pan/Shovel)
Andrews	28	
Andrews	32	
Crane	24	Time Savers
Crane	32	
H. D.	32	
S & S	32	
Rivera	40	Taper Lite

The following is sometimes mistaken for noisy tappets:

- The most common being the clearance between cam gear and pinion gear (referred to as gear lash). If you did not change the cam at the time of installing this kit and had no gear lash but a slight whine when motor was cold it is safe to say you are OK in this area.
- Rocker arm end play .004" to .010" is good.
- Oil pressure at normal operating temperature about 2000 r.p.m. should be 12-35 p.s.i. on Big Twin models, and 10-17 p.s.i. at 2500 r.p.m. on XL models.
- Check valve to guide clearance.

**"Doing It Right... The JIMS® Way!"**

555 Dawson Drive, Camarillo, CA 93012 • Phone 805-482-6913 • Fax 805-482-7422